

# Sintrol Dumo – the perfect tool for ambient dust monitoring



[www.sintrolproducts.com](http://www.sintrolproducts.com)



# Continuous Trend Monitoring For Ambient Dust

- Improve Employee Health Conditions
- Protect Your Equipment
- Cost friendly
- Easy to use
- Low maintenance

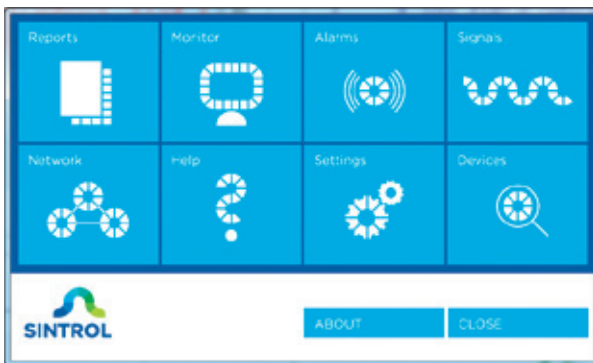

DustLog 8 menu

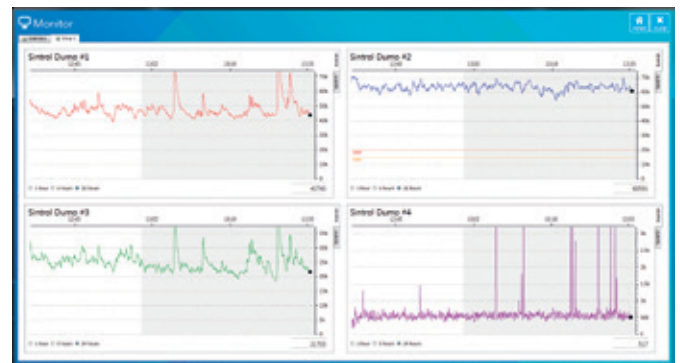

Datalogging chart

**Sintrol Dumo** monitors Total Suspended Particles (TSP) in ambient air based on the signal generated from moving particles. Test measurements in the laboratory and in the field proved that Dumo is capable of monitoring low dust concentrations and particle sizes as small as 0.3 micrometers. Dumo is easy to install and commission and virtually maintenance free. For parameterization and set up, Dumo can be accessed via USB with our **DustTool** software available free of charge from our website.

**Sintrol Dumo** has a standard 4-20 mA output, which can be easily integrated into existing systems such as a PLC in the control room. Dumo has “Alert” and “Alarm” functions corresponding to certain dust concentration levels above the normal levels identified using Dumo’s easy auto setup feature. The normal level is determined and fixed at the beginning of monitoring and the two alarm levels can be set during the commissioning. The instrument can also be set to show mg/m<sup>3</sup> by performing a reference measurement.

Ease of use makes this device ideal for applications where any disruption in the normal operation may result in an increase of particle concentration in the workplace causing nuisance and harm to people or machinery. In areas requiring dust extraction systems to lower particulate levels in the environment, **Sintrol Dumo** is the perfect complement to monitor the efficiency of dust removal.

Rising environmental regulations in ambient environments for worker health have increased the demand for particulate monitoring around the world in these applications. The **Sintrol Dumo** is the premier trend monitor to improve worker health and protect industrial equipment.

The new **DustLog 8** is a revolutionary data logging system and reporting tool that gives the user greater access to the monitor than ever before. Reports can be generated to see historical trends in the measurement with the ability to generate monthly, daily or hourly averages charted on nice graphs. Additionally, the easy user interface gives the plant full control of the device’s parameters so they can be read, sent or configured directly from the control room. After installation of the monitor, almost all access to the monitor can be done remotely using the **DustLog 8**.

With our new **IECEX/Atex certified** instrument, the Dumo can now be used in higher risk areas to detect abnormal levels of potentially explosive dust concentrations.

**Sintrol Dumo** is a useful tool in all work environments where harmful dust concentrations are encountered:

- Mines
- Foundries
- Wood
- Cotton processing
- Textile mills
- Food
- Chemical
- Paper mills
- Agricultural

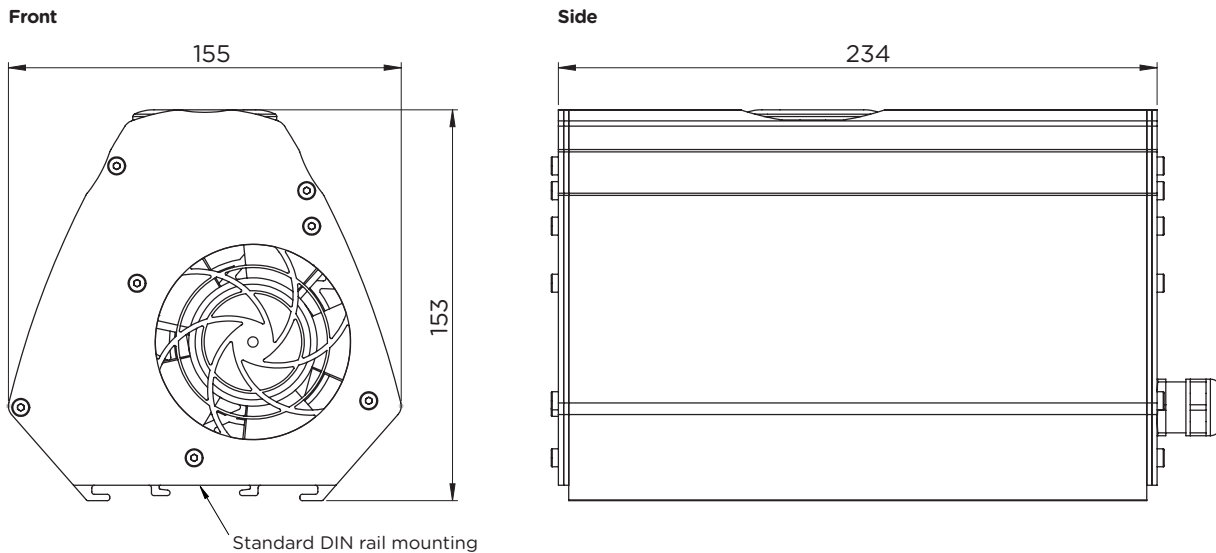

## Technical Specifications

Measurement Objects	Solid particles in ambient air
Particle Size	0.3 $\mu\text{m}$ or larger
Measurement Principle	Inductive Electrification
Protection Category	IP54
Power Supply	24 VDC
Power Consumption	5 W, (Dumo EX; 8 W)
Cable Connection	5 meter cable, 12 wires   16.4 ft cable, 12 wires
Output Signals	- Isolated 4 - 20 mA output - Two output signals, (100 - 280 mA) *
Communication Interface	- Serial communication RS-485 - USB communication - Radio frequency (RF) communication (optional)
Communication Protocol	- Modbus RTU, (RS-485) - SNT network, (USB, RF, RS-485)
Alarm Settings	- Automatic, set at factory: Based on average measured dust flow - User selectable ranges
Signal Damping Time	0 - 5400 s
<b>Ambient Conditions</b>	
Temperature	-20 to +60 $^{\circ}\text{C}$   -4 to 140 $^{\circ}\text{F}$
Humidity	95 % RH (non-condensing)
<b>Materials and Weight</b>	
Probe Material	Stainless steel (AISI 316L)
Body	Aluminum, stainless steel (AISI 316L)
Weight	4 kg   8.8 lb

\* Depending on operation temperature

## Principle of Operation

Sintrol dust monitors are based on a unique Inductive Electrification technology. The measurement is based on particles interacting with an isolated probe mounted into the duct or stack. When moving particles pass nearby or hit the probe a signal is induced. This signal is then processed through a series of Sintrol's advanced algorithms to filter out the noise and provide the most accurate dust measurement output.



## Sintrol

Ruosilantie 15,  
FI-00390 Helsinki, FINLAND  
Tel. +358 9 561 7360  
e-mail: [info@sintrolproducts.com](mailto:info@sintrolproducts.com)  
[www.sintrolproducts.com](http://www.sintrolproducts.com)