

REVO C 2PH



SIZE SR10



SIZE SR16



SIZE S14

Technical Specification

- Dimensions:** See size and dimensions page 8-9
- Load type:** Normal Resistance, Infrared Short, Medium and Long waveform
- Inputs:** 4:20mA, 0:10V, SSR and Modbus® as std and different Field Bus Listed in the Product Coding
- Firing mode:** Burst Firing, Zero Crossing.
- Control Mode:** Voltage, Current and Power or V2 and I2 with additional Transfer to VxI
- Communication:** RS485 port. RTU Modbus® Protocol and other Field Bus available
- USB:** port integrated for configuration in safety mode (No Load and Auxiliary Voltage needed) Unit Powered Through USB
- Approvals:** Comply with EMC, cUL us® 508 listed and cUL® listed
- 100 KA:** Short Circuit Current rating (SCCR) up to 600V

Option

- See below the types of options and their combination for Code generation
- Energy Totalizer
- Data Logging
- WiFi
- HB Alarm to diagnose partial or Total Load Failure and Thyristor Short Circuit

Tools

- A very easy and Powerful Configurator Software is available Free of Charge on www.cdautomation.com
- CD Automation APP is also available free of charge to communicate via Wi-Fi

No option Option selected (ex code 3: Logging + Totalizer)

HB	WIFI	LOGGING	TOTALIZER	CODE	NOTES
<input type="checkbox"/>	<input type="checkbox"/>	<input type="checkbox"/>	<input type="checkbox"/>	0	
<input type="checkbox"/>	<input type="checkbox"/>	<input type="checkbox"/>	<input type="checkbox"/>	1	HB Alarm for partial or total load failure and Short Circuit on SCR (relay output).
<input type="checkbox"/>	<input type="checkbox"/>	<input type="checkbox"/>	<input type="checkbox"/>	2	
<input type="checkbox"/>	<input type="checkbox"/>	<input type="checkbox"/>	<input type="checkbox"/>	3	WIFI Option that allows communication with a smart phone. From your smart phone via the CD Automation App, direct to your thyristor unit in the cabinet to read current, voltage, power and energy totalization as well as the ability to change parameters to improve process and product quality without opening the cabinet door.
<input type="checkbox"/>	<input type="checkbox"/>	<input type="checkbox"/>	<input type="checkbox"/>	4	
<input type="checkbox"/>	<input type="checkbox"/>	<input type="checkbox"/>	<input type="checkbox"/>	5	
<input type="checkbox"/>	<input type="checkbox"/>	<input type="checkbox"/>	<input type="checkbox"/>	6	
<input type="checkbox"/>	<input type="checkbox"/>	<input type="checkbox"/>	<input type="checkbox"/>	7	
<input type="checkbox"/>	<input type="checkbox"/>	<input type="checkbox"/>	<input type="checkbox"/>	8	APP Free of charge download it from Google Play or Apple Store.
<input type="checkbox"/>	<input type="checkbox"/>	<input type="checkbox"/>	<input type="checkbox"/>	9	
<input type="checkbox"/>	<input type="checkbox"/>	<input type="checkbox"/>	<input type="checkbox"/>	A	DATA LOGGER This feature is important to see the historical data of parameter like Current, Voltage and Power and can be useful to diagnose a fault.
<input type="checkbox"/>	<input type="checkbox"/>	<input type="checkbox"/>	<input type="checkbox"/>	B	
<input type="checkbox"/>	<input type="checkbox"/>	<input type="checkbox"/>	<input type="checkbox"/>	C	
<input type="checkbox"/>	<input type="checkbox"/>	<input type="checkbox"/>	<input type="checkbox"/>	D	ENERGY TOTALIZER This function totalize the energy consumption of the load allowing the calculation cost of heating treatment.
<input type="checkbox"/>	<input type="checkbox"/>	<input type="checkbox"/>	<input type="checkbox"/>	E	
<input type="checkbox"/>	<input type="checkbox"/>	<input type="checkbox"/>	<input type="checkbox"/>	F	

CONNECTIVITY

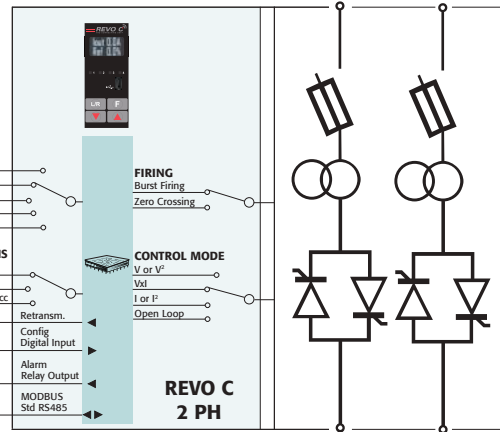

ORDER CODE:

	1	2	3	4	5	6		7	8	9	10	11	12	13	14	15	16
REVO C 2PH	R	C	2	-	-	-	-	-	-	-	-	-	-	-	-	-	-

CURRENT	FUSES	4	5	6
description	description	code	note	
30A	Fuse + Fuse Holder Included	0 3 0		
35A	Fuse + Fuse Holder Included	0 3 5		
40A	Fuse + Fuse Holder Included	0 4 0		
60A	Fixed Fuses Included	0 6 0		
90A	Fixed Fuses Included	0 9 0		
120A	Fixed Fuses Included	1 2 0		
150A	Fixed Fuses Included	1 5 0		
180A	Fixed Fuses Included	1 8 0		
210A	Fixed Fuses Included	2 1 0		
300A	Fixed Fuses Included	3 0 0		
400A	Fixed Fuses Included	4 0 0		
450A	Fixed Fuses Included	4 5 0		
500A	Fixed Fuses Included	5 0 0		
600A	Fixed Fuses Included	6 0 0		
700A	Fixed Fuses Included	7 0 0		
800A	Fixed Fuses Included	8 0 0	5	

For Extended version (from 1100A to 2100A) see page 18

MAX VOLTAGE	7
description	code
480V	4
600V	6
690V	7 1,2

MAIN SUPPLY VOLTAGE	AUX VOLTAGE RANGE	8
description	V range	code
100/120Vac	90 to 135Vac	1 3
200/208/230/240Vac	180 to 265Vac	2 3
277Vac	238 to 330Vac	3 3
380/415/480Vac	342 to 528Vac	5 3
600Vac	540 to 759Vac	6 3
690Vac	540 to 759Vac	7 3

MAIN INPUT	9
description	code
SSR	S
0:20mA	B
4:20mA	A
0:10V	V
10KPot	K

FIRING	START OPTION	10
description	description	code
Burst Firing	No Soft Start	B
Zero Crossing	No Soft Start	Z

CONTROL MODE	11
description	code
Open Loop	0
Voltage	U
Voltage Square	Q
Current	I
Current Square	A
Power VxI	W

OPTION	12
description	code
No Option	0
Option code - see previous page table	...

FAN VOLTAGE	13
description	code
No Fan < 90A 480V/600V	0
Fan 115Vac ≥ 90A 480V/600V - ≥ 60A 690V	1
Fan 230Vac ≥ 90A 480V/600V - ≥ 60A 690V Std Version	2
Fan 24Vdc ≥ 90A 480V/600V - ≥ 60A 690V	3

APPROVALS	14
description	code
CE EMC For European Market	0
CUL us* + CE EMC For American & European Market	L

LOAD TYPE	15
description	code
Normal Resistive Load with 3 Phase Star without neutral Connection	0
Normal Resistive Load with 3 Phase Delta Connection	1
IRSW Infrared Short wave with 3 Phase Star Connection	2
IRSW Infrared Short wave with 3 Phase Delta Connection	3

COMMUNICATION AND RETRANSMISSION	16	
description	description	code
N°1 Modbus® RTU	No Retransmission	0
	Retransmission 4:20mA	1
	Retransmission 0:10V	2
N°2 Modbus® RTU	No Retransmission	3 4
	Retransmission 4:20mA	4 4
	Retransmission 0:10V	5 4
N°1 Profibus® DP	No Retransmission	6 4
	Retransmission 4:20mA	7 4
	Retransmission 0:10V	8 4
N°1 Profinet® IO	No Retransmission	9 4
	Retransmission 4:20mA	A 4
	Retransmission 0:10V	B 4
N°1 Modbus® TCP	No Retransmission	C 4
	Retransmission 4:20mA	D 4
	Retransmission 0:10V	E 4
N°1 Ethernet IP + N°1 Modbus® RTU	No Retransmission	F 2
	Retransmission 4:20mA	G 2
	Retransmission 0:10V	H 2

Note (1): No cUL/UL approved
Note (2): Available on unit ≥60A
Note (3): Main Supply Voltage has to be included in Auxiliary Voltage range
Note (4): 24Vdc Backup Power for User Interface and Communications included
Note (5): Only CE and UL approved, not cUL

FEATURES

View with IP20 protection



Standard Version with IP0



TECHNICAL SPECIFICATION

OPERATING TEMPERATURE	from 0 to +40°C, over this temperature see derating curve at page 23
MAX VOLTAGE POWER SUPPLY	480V, 600V or 690V
AUXILIARY VOLTAGE SUPPLY	90÷265V, 20 VA power consumption. Fan voltage supply: 230±15% as a standard and 110V on request
ANALOG INPUT	1 main reference, 4÷20mA, 0÷10V, 10KPOT, RS485 port
ANALOG INPUT 2	Secondary reference, 0÷10V, 10KPOT
DIGITAL INPUT	Two optoisolated digital input (12/24Vdc), for Start, Stop, Enable, Calibration, Reset Alarm and External Alarm or other function that can be implemented (ex. Switch from one firing to another)
RELAY OUTPUT	Three configurable relay output and one critical alarm
UNIVERSAL FIRING	One of these firing modes can be configured burst firing BF, delayed triggering and phase angle on 1-3 PH units (see on left page)
COMMUNICATION	RS485 port. Modbus communication plus different FieldBus (see Order Code)
UNBALANCED LOAD	This protection allow to have REVO C working up to 20% of unbalance on one phase
CONTROL MODE	Voltage (V), Current (I), Power (VxI), external feed-back, Voltage Square and Current Square
HEATER BREAK	Alarm to diagnose partial or total load failure and short circuit on thyristor
THERMAL PROTECTION	Thermal switch 1 for Overtemperature Alarms std Thermal switch 2 for Alarm and Trip std

REVO C FEATURES AND DIMENSIONS

		DESCRIPTION	REVO C 1PH		REVO C 2PH		REVO C 3PH	
		CODE	RC1	RC2	RC2	RC3	RC3	RC3
LOAD TYPE	Max voltage 480V		●		●		●	
	Max voltage 600V		●		●		●	
	Max voltage 690V		●		●		●	
	Single phase		●					
	3 phase load star no neutral or delta				●		●	
	3 phase load star with neutral						●	
	3 phase load open delta		● ⁽¹⁾					
INPUT TYPE	SSR 4:30VDC		●		●		●	
	4:20 mA		●		●		●	
	0:10 Vdc		●		●		●	
	Potentiometer		●		●		●	
FIRING	Single Cycle		●					
	Half Cycle		●					
	Burst Firing		●		●		●	
	Phase Angle		●				●	
	Delayed Triggering		●				●	
	Zero Crossing		●		●		●	
CONTROL MODE	Open Loop		●		●		●	
	Voltage		●		●		●	
	Voltage square		●		●		●	
	Current		●		●		●	
	Current Square		●		●		●	
	Power V x I		●		●		●	
OPTIONS	Current Limit CL		○				○	
	Heater Break Alarm + SCR Short Circuit		○		○		○	
	WiFi		○		○		○	
	Logging		○		○		○	
	Totalizer		○		○		○	
COMM.	Modbus® RTU		○		○		○	
	Profibus® DP + 1 Modbus® RTU		○		○		○	
	2 Profinet® IO + 1 Modbus® RTU		○		○		○	
	2 Modbus® TCP + 1 Modbus® RTU		○		○		○	
CURRENT		CURRENT	SIZE		SIZE		SIZE	
			600V Max	690V	600V Max	690V	600V Max	690V
		30	SR9		SR10		SR11	
		35	SR9		SR10		SR11	
		40	SR9		SR10		SR11	
		60	SR12	S11	SR13	S11	SR14	S11
		90	SR15	S11	SR16	S11	SR17	S11
		120	SR15	S11	SR16	S13	SR17	S13
		150	SR15	S11	SR16	S13	SR17	S13
		180	SR15	S11	SR16	S13	SR17	S13
		210	SR15	S11	SR16	S13	SR17	S13
		300	S12		S14	S14	S14	S14
		400	S12	S12	S14	S14	S14	S14
		450			S14	S14	S14	S14
		500	S12	S12	S14	S14	S14	S14
		600	S12	S12	S14	S14	S17*	S17
		700	S12	S12	S14	S14	S17*	S17
		800	S15*	S15	S16*	S16	S17*	S17
		1100	SR18*	SR18	SR19*	SR19	SR20*	SR20
		1400	SR21*	SR21	SR22*	SR22	SR23*	SR23
		1600	SR21*	SR21	SR22*	SR22	SR23*	SR23
	1800	SR21*	SR21	SR22*	SR22	SR23*	SR23	
	2100	SR21*	SR21	SR22*	SR22	SR23*	SR23	

● Standard ○ Option ■ CE standard + cUL® as an option ■ CE Only - **Note (1):** Use n° 3 Revo-C 1PH *UL approval as option

Agency Approval and Regulatory: cULus 508 Listed File E231578; cUL® Listed to C22.2 No. 14; CE EMC Directive 2014-30-EU, EN 60947-4-3 Class A Emissions; CE Safety Directive 2014-35-EU, EN 60947-4-1, -4-3; RoHS 2011-65-EU; W.E.E 2012-19-EU

REVO C FAMILY SIZE AND DIMENSIONS

REVO Connect is a fully universal product range based upon powerful microprocessor technology. Available from 30A to 2100A and single phase (1PH) plus 2PH & 3PH to drive 3 phase loads, its key benefit is its connectivity with the outside world, through Wi-Fi and the most popular Field Bus Protocols. Its universality allows inputs, all firing and control modes to be configured via Smart phone using CD Automation's Connect-APP or via your personal computer and CD Automation's Configurator Software. CD Automation's APP and Configurator Software are available free of charge.

When you buy REVO-C, you also buy CD Automation's experience and know-how to drive your application.



SR9 H 121 x W 72 x D 185 - 1,15kg.



SR10 H 121 x W 108 x D 185 - 1,76kg.



SR11 H 121 x W 144 x D 185 - 2,4kg.



SR12 H 269 x W 93 x D 170 - 3,4kg.



SR13 H 269 x W 186 x D 170 - 6,8kg.



SR14 H 269 x W 279 x D 170 - 10,2kg.

SR15 H 273 x W 93 x D 170 - 3,6kg.

SR16 H 273 x W 186 x D 170 - 7,0kg.

SR17 H 273 x W 279 x D 170 - 10,6kg.



S11 H 440 x W 137 x D 270 - 10,5kg.



S12 H 520 x W 137 x D 270 - 15kg.



S13/S14 H 440/520 x W 262 x D 270 - 18/22kg.



S15 H 560 x W 137 x D 270 - 17,2kg.



S16 H 560 x W 275 x D 270 - 34,4kg.



S17 H 560 x W 411 x D 270 - 51,6kg.



SR18 H 550 x W 329 x D 347 - 27kg.



SR19 H 550 x W 523 x D 347 - 49kg.



SR20 H 550 x W 717 x D 347 - 72kg.



SR21 H 730 x W 329 x D 347 - 34kg.



SR22 H 730 x W 523 x D 347 - 65kg.



SR23 H 730 x W 717 x D 347 - 98kg.